

Installation Note

**Agilent Technologies
E4402B Spectrum Analyzer and
E7402A EMC Analyzer
Low Frequency Extension (Option UKB)
Retrofit Kit**



Agilent Technologies

Part Number E4402-90095 Supersedes: E4402-90093, E7402-90002
Printed in USA August 2003



E4402-90095

Notice.

The information contained in this document is subject to change without notice.

Agilent Technologies makes no warranty of any kind with regard to this material, including but not limited to, the implied warranties of merchantability and fitness for a particular purpose. Agilent Technologies shall not be liable for errors contained herein or for incidental or consequential damages in connection with the furnishing, performance, or use of this material.

Introduction

This procedure can be used to retrofit the 100 Hz Low Frequency Extension (Option UKB) into your analyzer.

Products Affected:	E4402B E7402A
Serial Numbers:.....	US00000000/US99999999 MY00000000/MY99999999
Options:	UKB
To Be Performed By:	(X) Agilent Technologies Service Center (X) Personnel Qualified by Agilent () Customer
Estimated Installation Time:	3.0 Hours
Estimated Verification Time:	2.0 Hours

Installation Kit Parts List

Item	Description	Part Number
1	Input Attenuator, five section (A8A5)	33321-60052
2	Cable Assembly, Filtered Low Band RF Input (W35)	E4403-20058
3	Cable Assembly, RF Attenuator Output (W15)	E4403-20059
4	Cable Assembly, RF Input (W6)	E4404-20009
5	Cable Assembly, Attenuator/Second Converter Power and Control (W5)	E4404-60004
6	Connector Label, Option UKB (A1MP21)	E4403-80015
7	Nameplate, E4402B Option UKB (A1MP16)	E4402-80016 ^a
8	Nameplate, E7402A Option UKB (A1MP16)	E7402-80002 ^b
9	Micro Bracket (A8MP1)	E4404-00001
10	Sub Bracket (A8MP2)	E4404-00003
11	Filter Clamp (A8MP3)	5022-3619
12	Machine Screw, 3.0 mm x 10 mm Pan Head Torx (Qty 4)	0515-0374
13	Machine Screw, 3.0 mm x 8 mm Pan Head Torx (Qty 4)	0515-0372
14	Option UKB Installation Note	this note
15	Option Upgrade Entitlement Certificate	---

- a. ESA unique material
b. EMC unique material

NOTE After the hardware modifications have been made and Option UKB has been activated, you must adjust the frequency response of the analyzer. Adjustment Software is required to perform this adjustment, but is not included in this kit. The Performance Verification and Adjustment Software may be obtained by ordering the Service documentation and Software (Option 0BW).

Tools Required

- T-10 TORX screwdriver
- T-15 TORX screwdriver
- Flat-blade screwdriver
- Sharp knife or razor blade
- Function Generator
- Synthesized Sweeper
- Digital Voltmeter
- Power Meter, Dual-Channel
- RF Power Sensor (2 required)
- 50 Ω Termination
- Power Splitter
- 20 dB Attenuator
- APC 3.5 (m) Cable Assembly
- APC 3.5 (m) to Type N (m) Adapter
- APC 3.5 (m) to Type N (f) Adapter
- BNC Tee (f,m,f)
- Dual Banana to BNC (f) Adapter
- Adjustment Software

The Performance Verification and Adjustment Software may be obtained by ordering the Service documentation and Software (Option 0BW).

Torque Settings

To avoid potential RFI leakage and prevent connector damage, tighten to the following torque limits:

Item	Torque	
	In-lb	N-cm
SMA Connectors	8.5	95
3-mm, T-10 TORX screws	9	102
4-mm, T-15 TORX screws	21	236

Procedure

Verify A8A1 3 GHz RF Assembly Part Number

1. Turn on the analyzer and wait for the initial adjustments to complete.
2. Press **System, More, Show Hdwr**. This displays the Show Hardware screen, which lists the part number and serial number of most of the installed board assemblies.
3. Locate the part number of the “50Ω 3 GHz Input” assembly.
4. If the part number of the 50Ω 3 GHz Input assembly is E4403-60033 or lower, the A8A1 3 GHz RF assembly must be replaced. If the analyzer does not have the High Stability Frequency Reference, Option 1D5, order E4403-60073. If the analyzer does have Option 1D5, order E4403-60074.

WARNING Before you disassemble the instrument, turn the power switch OFF and unplug the instrument. Failure to unplug the instrument can result in personal injury.

CAUTION Electrostatic discharge (ESD) can damage or destroy electronic components. All work on electronic assemblies should be performed at a static-safe workstation. Refer to the documentation that pertains to your instrument for information about static-safe workstations and ordering static-safe accessories.

Dress Cover Removal

1. Refer to Figure 1 and disconnect the analyzer from ac power (1).
2. Remove any adapters or cables (2) connected to the front frame.
3. Carefully place the analyzer on the work surface with the front frame (3) facing down.
4. Position the handle (4) as shown.
5. Remove the four screws (5) that hold the rear frame and dress cover in place.
6. Remove the rear frame (6).
7. Pull the dress cover (7) off towards the rear of the analyzer.

Figure 1 Dress Cover and Rear Frame Removal

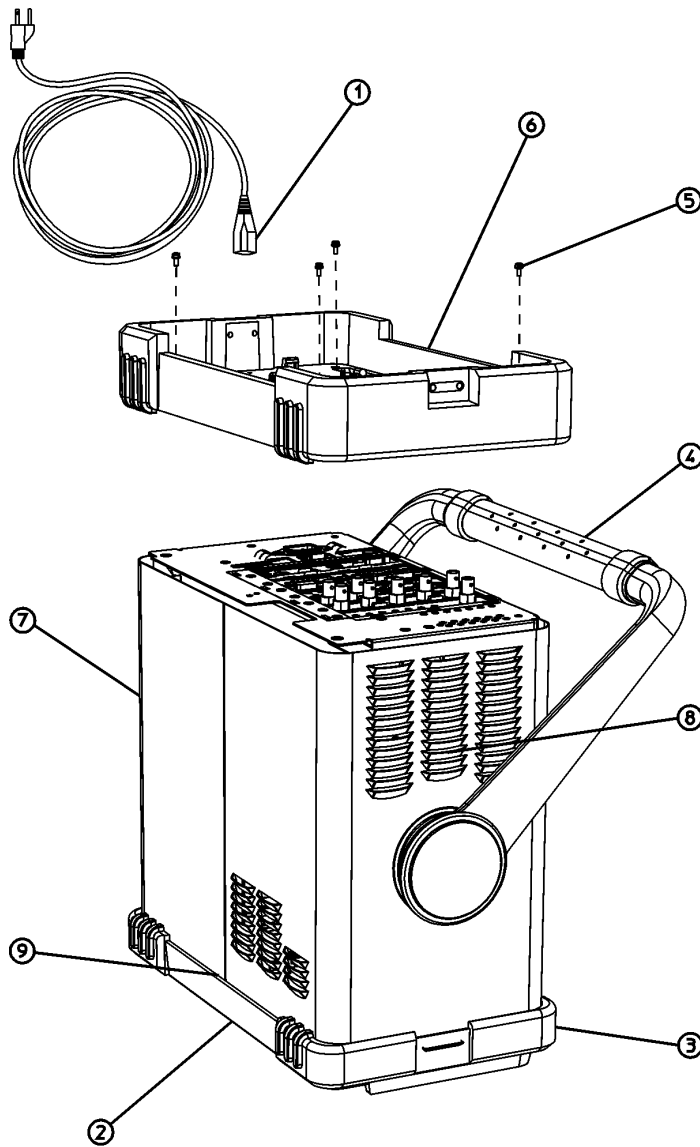

si745b

Chassis Cover Removal

1. Refer to Figure 2 and lay the analyzer flat.
2. Remove the 15 screws (2) and (3) attaching the chassis cover to the chassis. Note that the number of screws attaching the chassis cover may vary depending upon which options are installed.
3. Remove the chassis cover (1) from the chassis.

Figure 2 Chassis Cover Removal

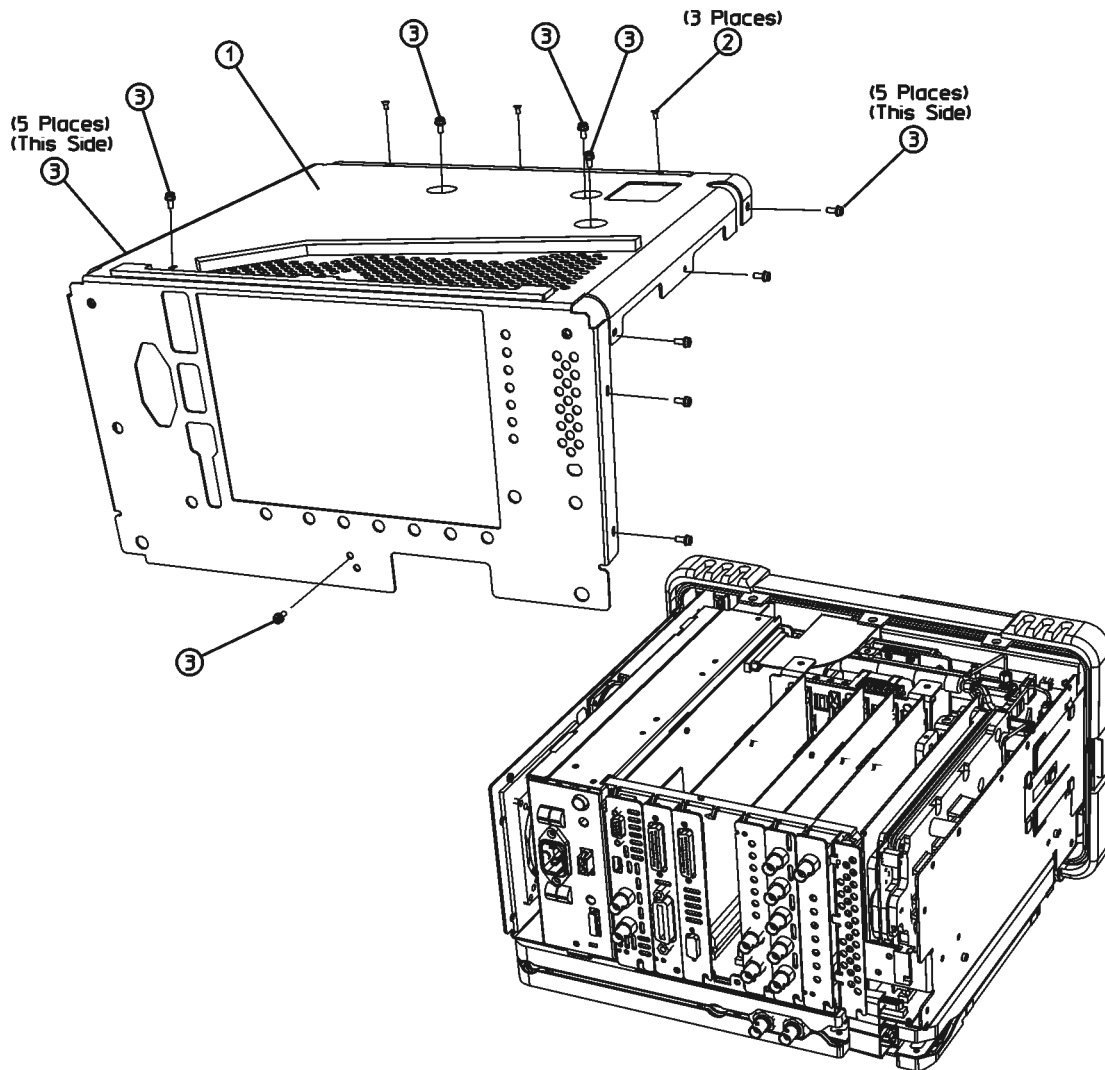

dl72b

A1 Front Frame Assembly

CAUTION Use ESD precautions when performing this replacement procedure.

The A1 front frame assembly can be extended from the instrument without detaching any connections.

1. Refer to Figure 3. Remove the two screws (1), on the bottom side of the instrument that secure the front frame to the RF assembly.

Figure 3 A1 Front Frame Assembly Removal

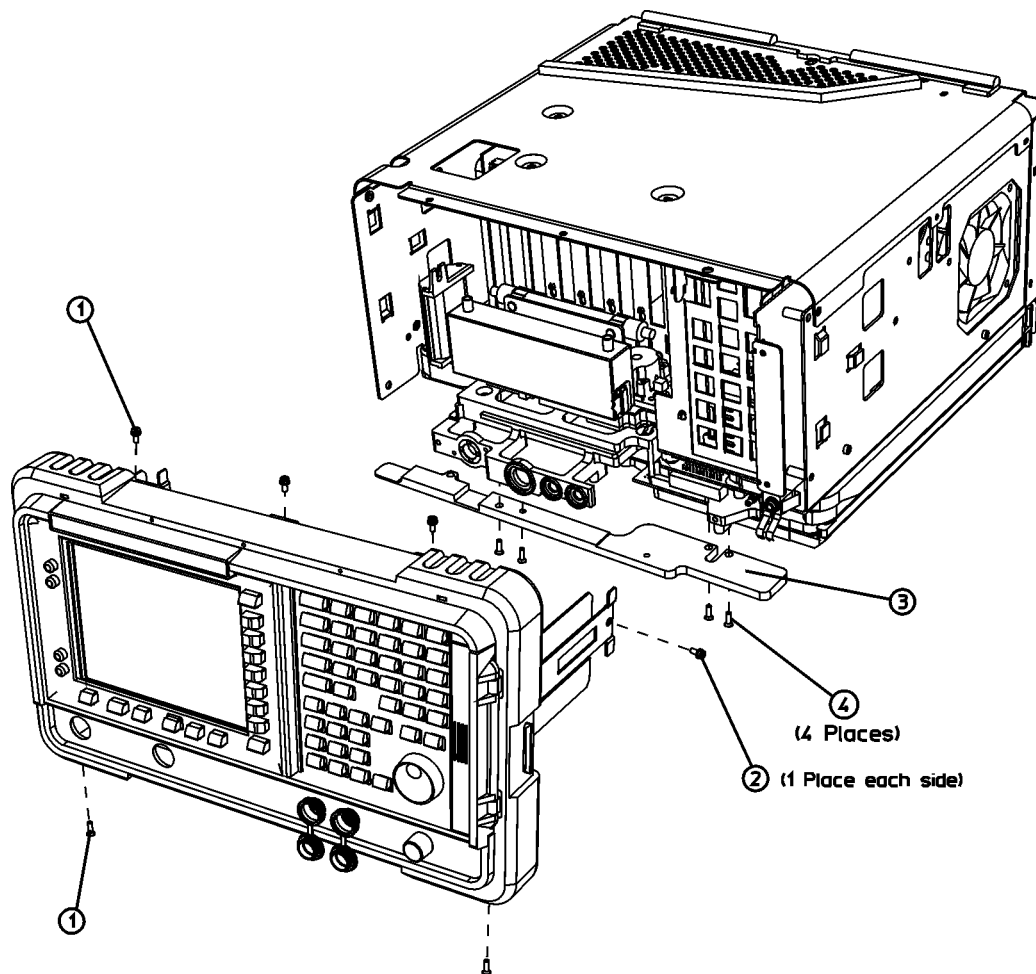

sl7118b

2. Place the instrument with the top side facing up and remove the remaining two screws (2) that secure the front frame subpanel to the chassis.
3. Slide the front frame forward until it catches on the tabs on the sides of the chassis.

4. Refer to Figure 4. Disconnect the ribbon cable (1) from the A1A1 front panel interface board.

NOTE Analyzers with Option B7B will have a second ribbon cable connecting to A1A1. Disconnect the second ribbon cable if present.

Figure 4 **Front Frame Ribbon Cable**

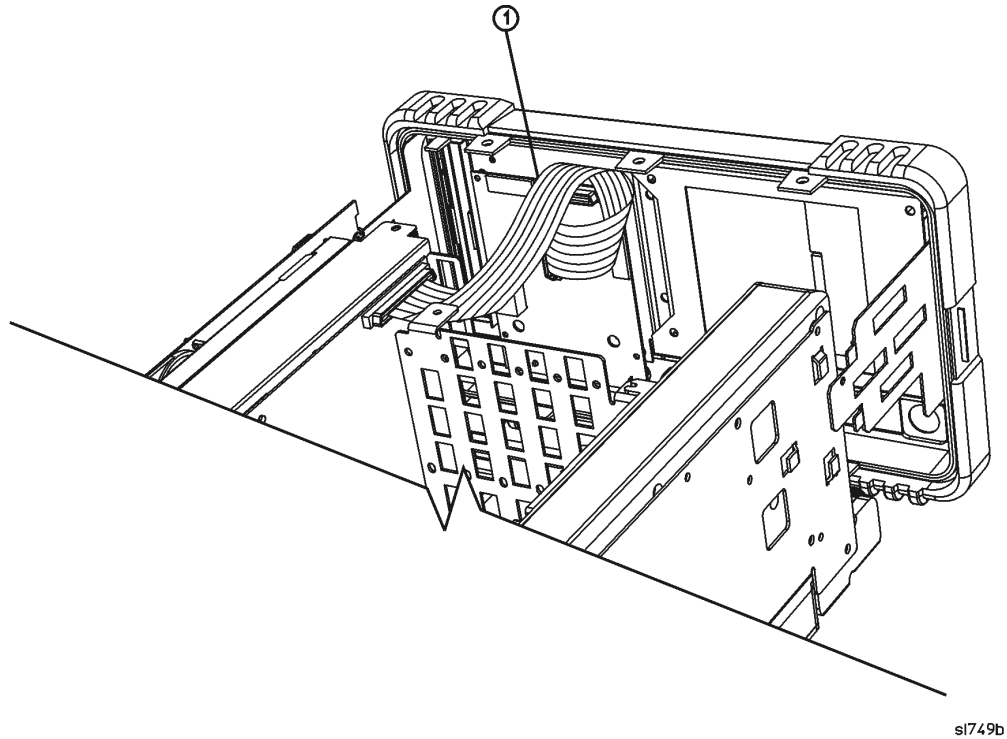

5. Carefully pull the sides of the front frame subpanel away from the chassis and over the tabs on the chassis.
6. Slide the front frame forward to disengage from the chassis assembly.

A1A1 Front Panel Interface Board Removal

1. Refer to Figure 5. Remove the disk drive door (1).
2. Remove the RPG knob (2).
3. Remove the volume knob (3).

NOTE You may need to exert considerable force in order to remove the RPG knob. It may be necessary to pry it off using a screwdriver as shown in Figure 5.

Figure 5 Removing the Front Frame Knobs

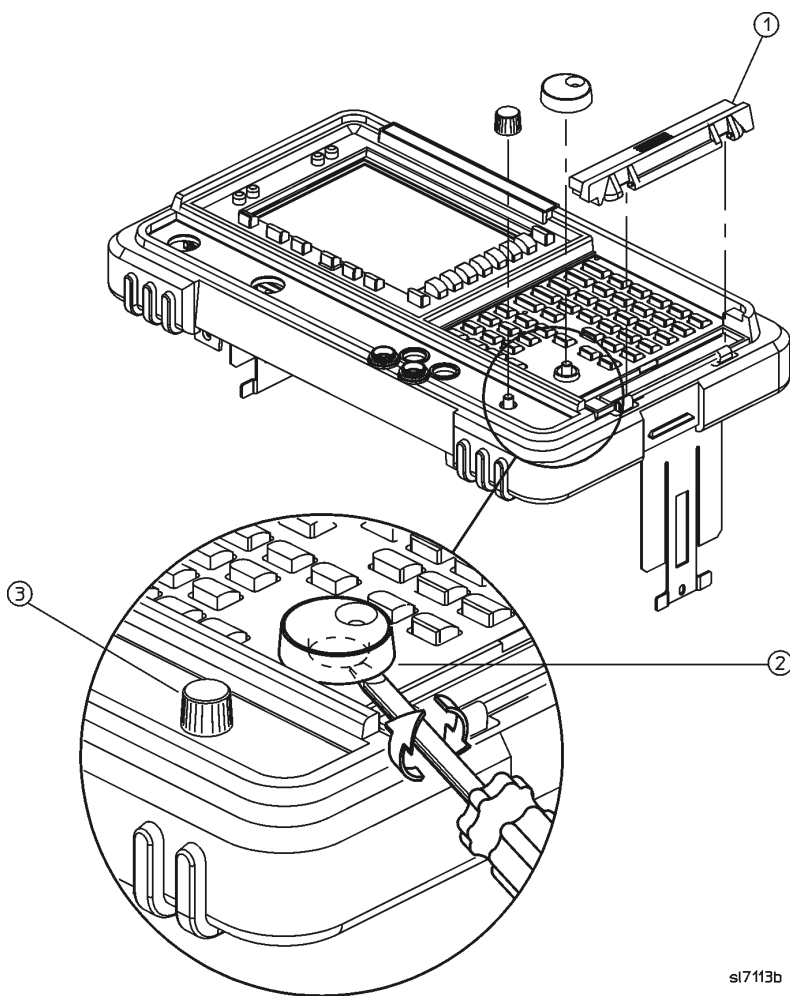

4. Refer to Figure 6. Disconnect the two 2-wire backlight cables (1) from the front panel interface inverter board.
5. Disconnect W3 ribbon cable (2) from the front panel interface board.

NOTE The W3 display ribbon cable connector (2) is delicate. With a small screwdriver or similar tool, gently push the lock tabs out from the back of the connector. Excessive force on the locking tab can break the retaining clips, and if broken, board replacement will be necessary.

Figure 6 **Disconnecting the Front Frame Wiring Connections**

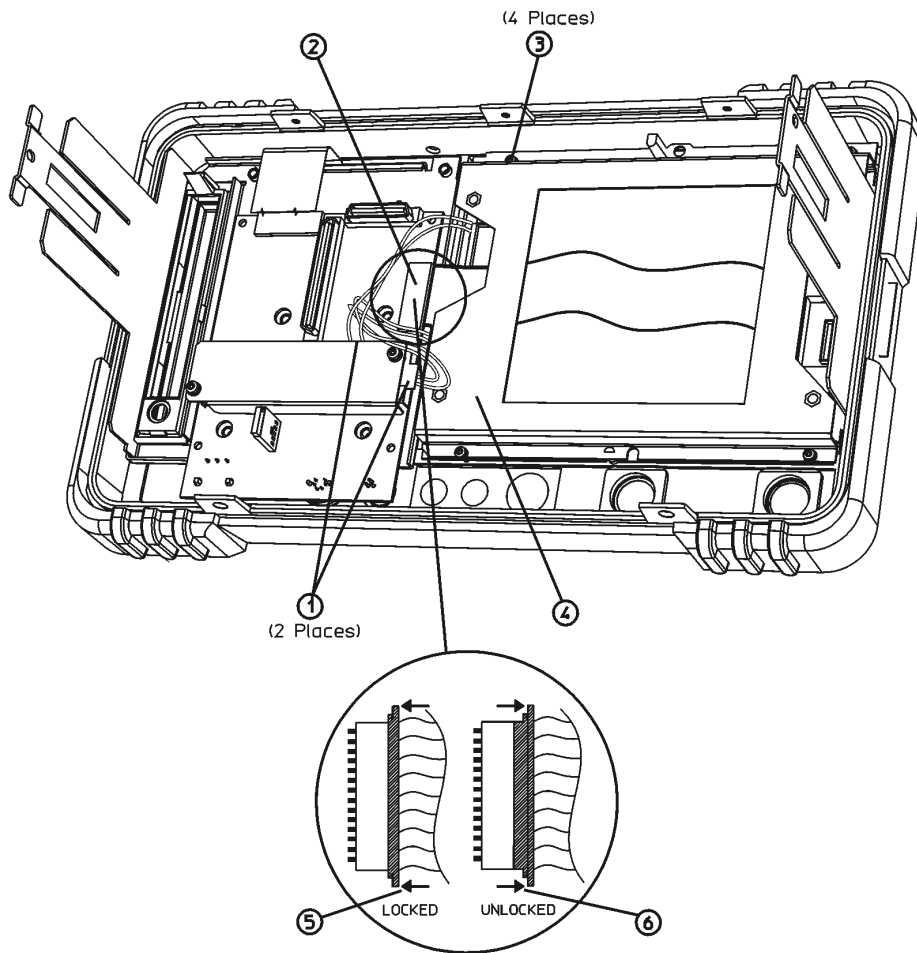

sl748b

6. Refer to Figure 7. Remove the four screws (10) that secure the A1A1 front panel interface board (11) to the front frame.
7. Remove the front panel interface board from the front frame assembly.

NOTE There is a water-seal gasket placed around the volume control shaft that will need to be repositioned during the replacement procedure.

Figure 7 Front Frame Assembly Parts

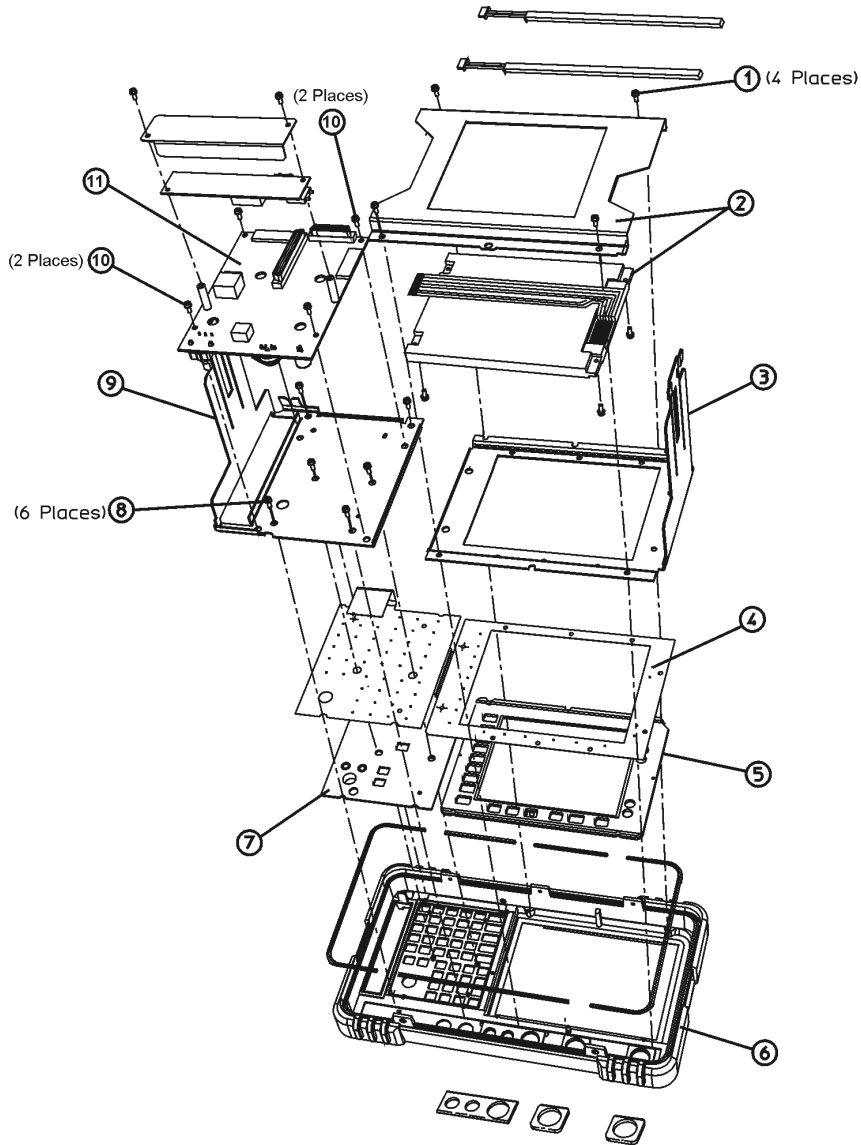

jl73a

Attach Nameplate to Front Frame

1. Locate the nameplate in the kit. The nameplate is labelled with the analyzer product number and the frequency range of the analyzer.
2. Refer to Figure 8 and remove the existing nameplate (1).
3. Clean the surface (2) of any adhesive residue.
4. Peel the backing (3) off the new nameplate and place it (4) as shown.

Figure 8 **Nameplate Replacement**

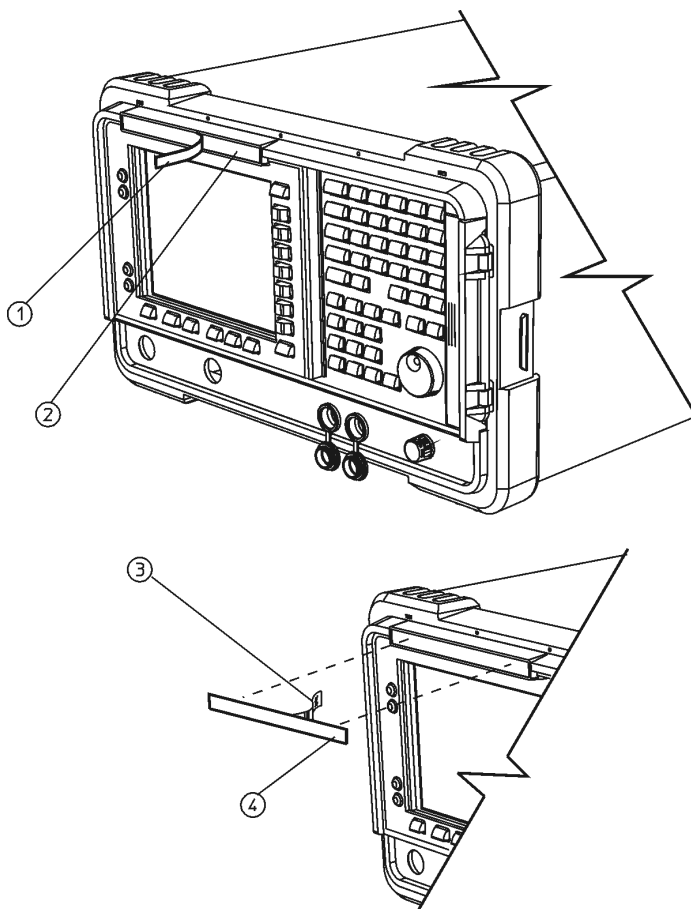

sl7114b

Attach Connector Label and Connector Covers to Front Frame

1. Locate the connector label in the kit. The connector label has holes to accommodate the various front panel connectors and the volume control. The frequency range of the analyzer appears near the hole next to the INPUT connector.
2. Refer to Figure 9. If the analyzer does not have a tracking generator, remove the hole plug for the RF OUT connector.
3. Remove the two connector covers from the front panel by pinching them from the sides and removing them (4) through the front of the front frame assembly.

Figure 9 Connector Covers

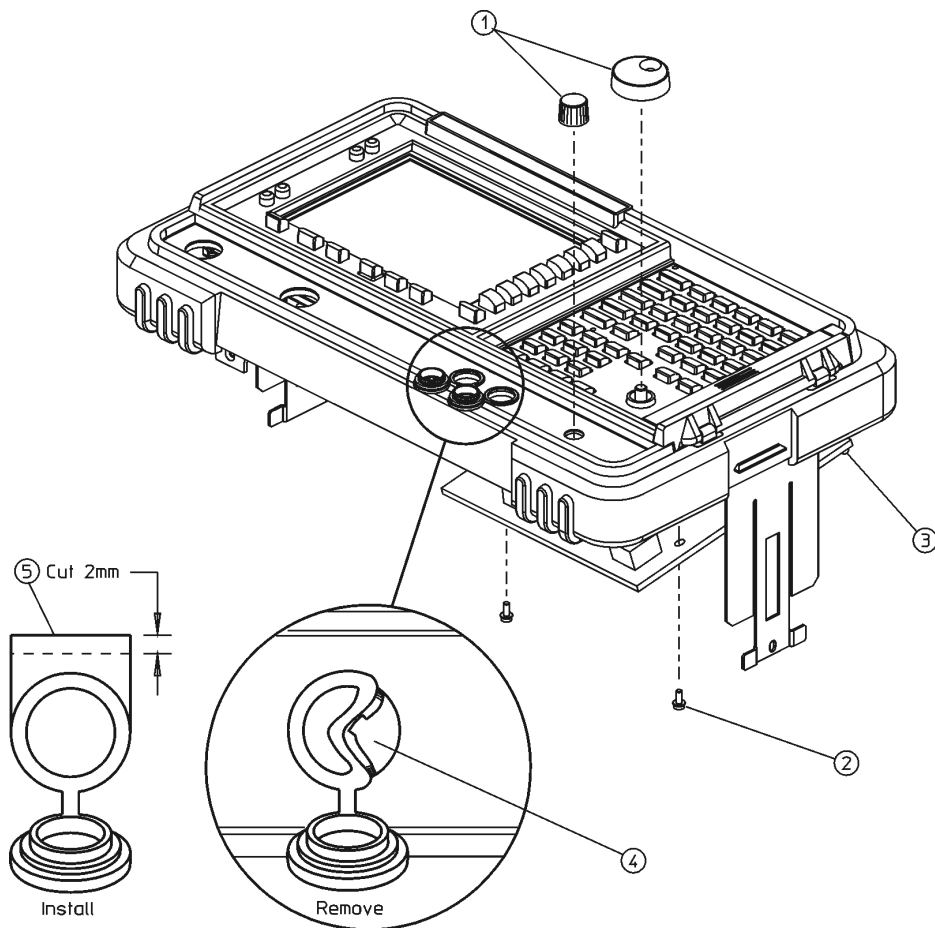

sl711b

4. Refer to Figure 10.
5. Peel off the old connector label loosening any residual adhesive with a sharp knife or razor blade as you go.
6. Before installing the new connector label, make sure the surface is free of any adhesive residue left from the old label. Failure to do so may result in an uneven (lumpy) appearance of the new label.

Figure 10 Connector Label Installation

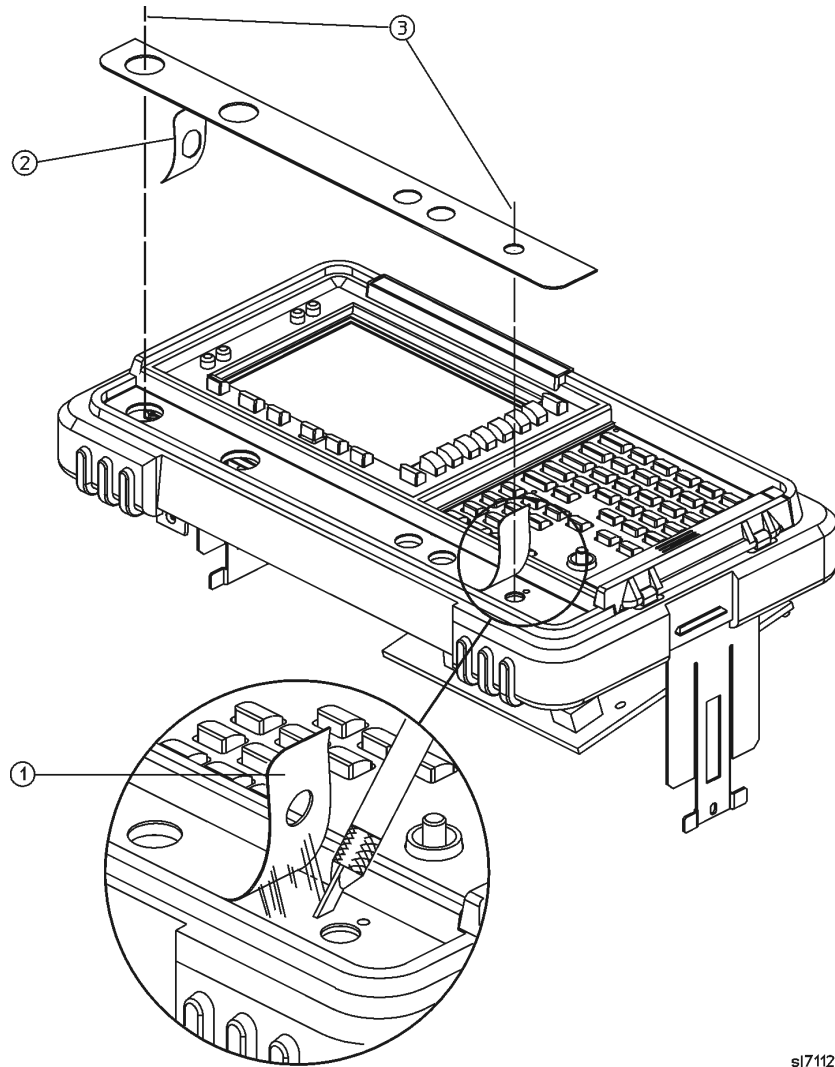

sl7112b

7. Peel the backing (2) off the new label, as shown.
8. Align and install the label by placing a finger in the RF OUT and VOLUME holes (3). Observe the alignment of the INPUT and PROBE POWER holes.
9. Refer to Figure 9. Reinstall the two connector covers from the front panel by pinching them from the sides and installing them through the front of the assembly.

TIP It may be helpful to trim off approximately 2 mm of the tabs (5) on the connector covers prior to reinstalling them. This will help in aligning the covers.

10. Align the connector covers so they open downward.
11. Reinstall the hole plug that was removed if your analyzer does not have a tracking generator.

Remove the 3.0 GHz RF Assembly

1. Refer to Figure 11. Disconnect the SMB cable (1) from the IF assembly.
2. Disconnect the RF assembly ribbon cable (2).

Figure 11 **Disconnect the RF Assembly Ribbon Cable**

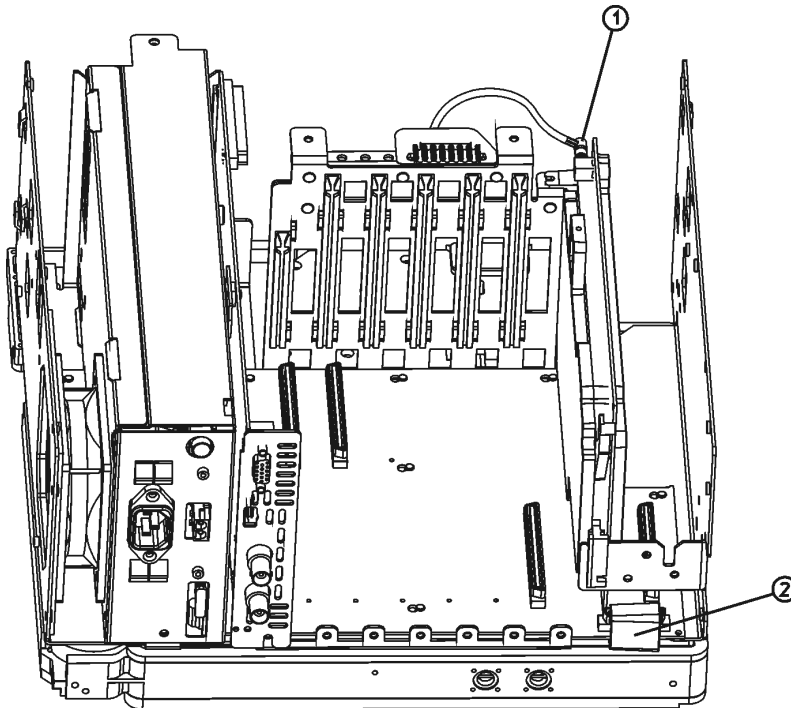

sl771b

3. Refer to Figure 12. If the analyzer has a tracking generator, disconnect the cables (1) and (2) from the tracking generator connector. Tuck the cable end with the yellow tag away behind the microcircuits of the RF assembly.

Figure 12 Disconnect the Tracking Generator Cables

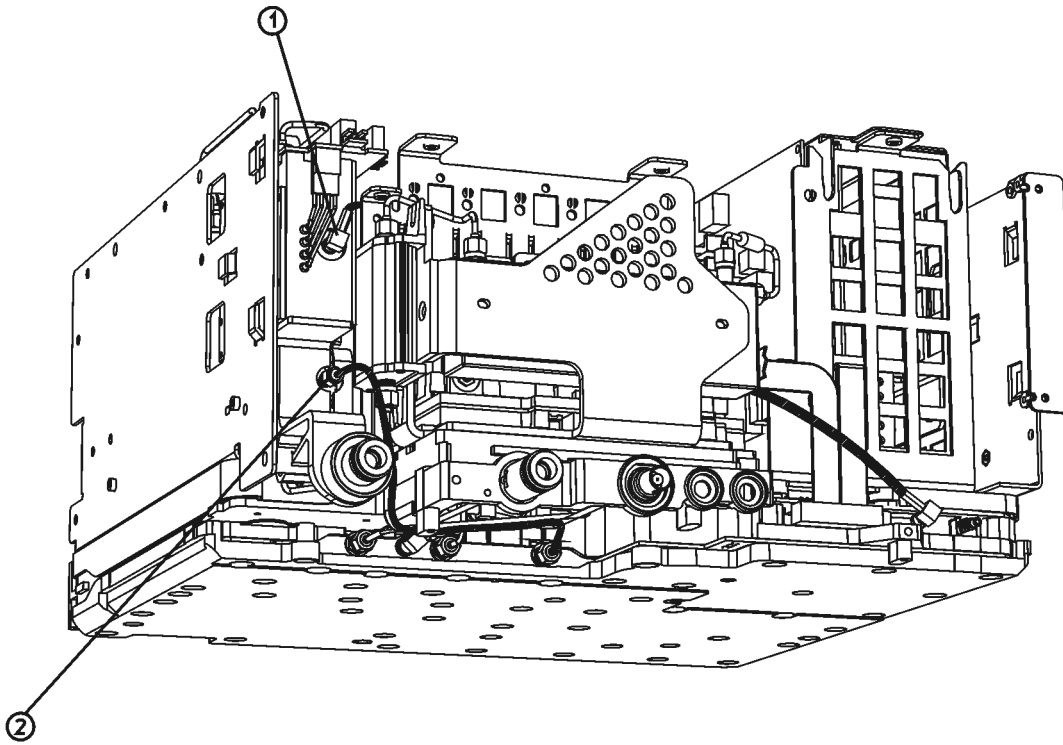

sl789b

4. Refer to Figure 13. Put the analyzer upside down and remove the six screws (1) marked “RF Deck” securing the RF assembly to the chassis.
5. Carefully lift the RF assembly from the chassis.

CAUTION The cables and assemblies are easily damaged. Once removed, it is best to lay the RF assembly flat on a work surface. Do not rest it against any of the microcircuits or cables.

Figure 13 Remove the RF Deck Screws

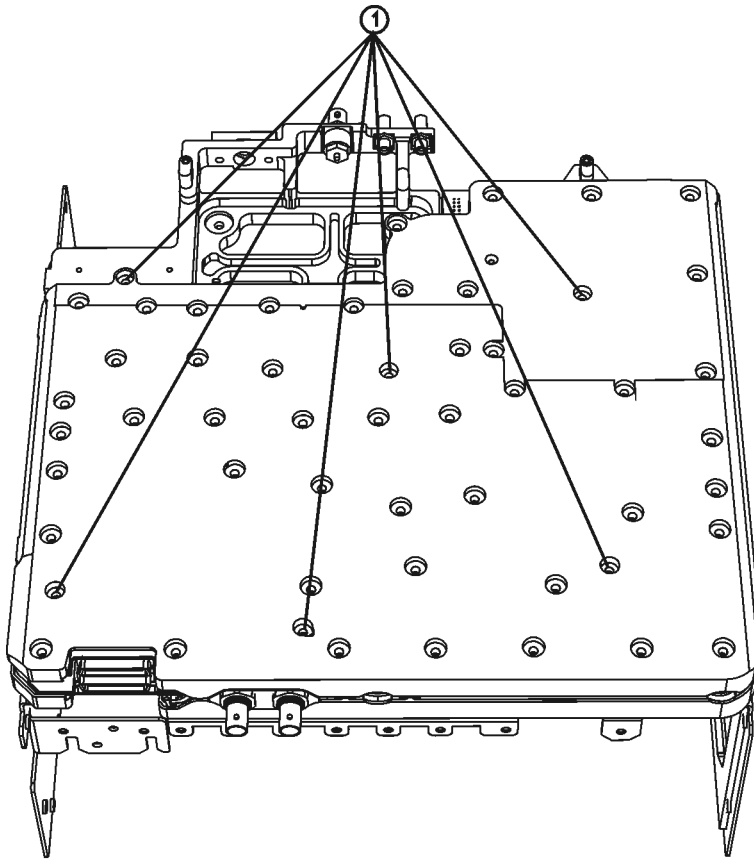

sl779b

Remove Low Pass Filter and Second Converter

1. Position the 3 GHz RF Assembly as shown in Figure 14. Disconnect the flexible coax cable, W10 (4) from the bottom of the A8A2 Second Converter.
2. Disconnect the end of W8 (1) connected to A8A1.

Figure 14 **Disconnect the Filter and Converter Cables**

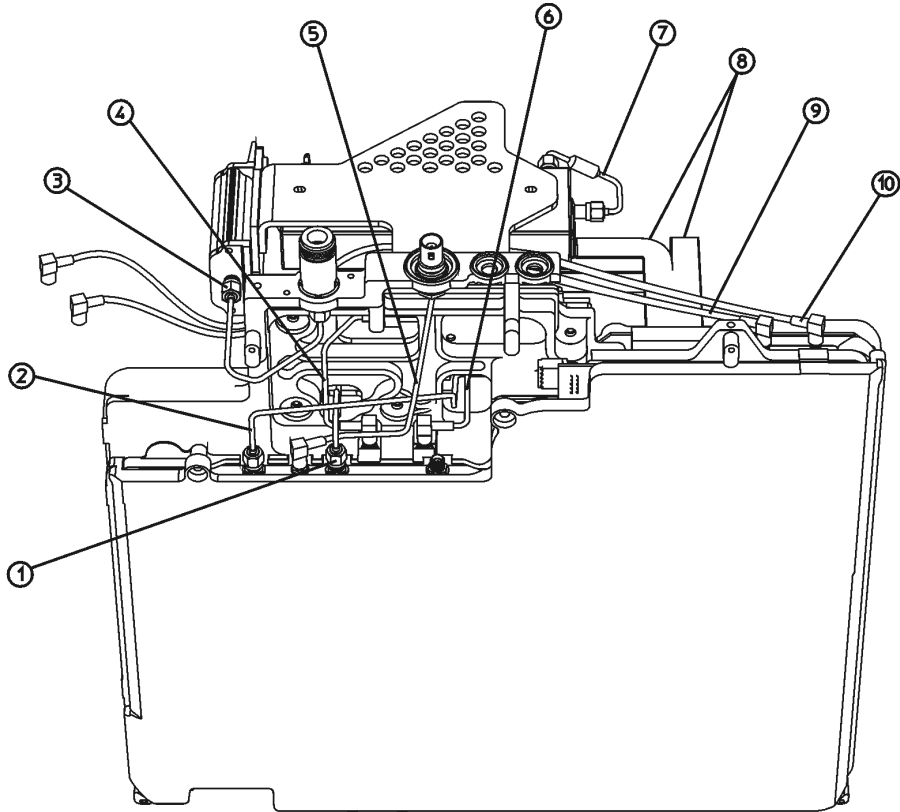

si714b

3. Disconnect the end of W9 (2) connected to A8A1.
4. Disconnect the end of W11 (6) connected to A8A1.

- Position the 3 GHz RF Assembly as shown in Figure 15. Remove the two semi-rigid coax cables, W15 (5) and W8 (12), that connect to the A8FL1 Low Pass Filter (8). These cables will not be reused.

Figure 15 Disconnect the RF Assembly Cables

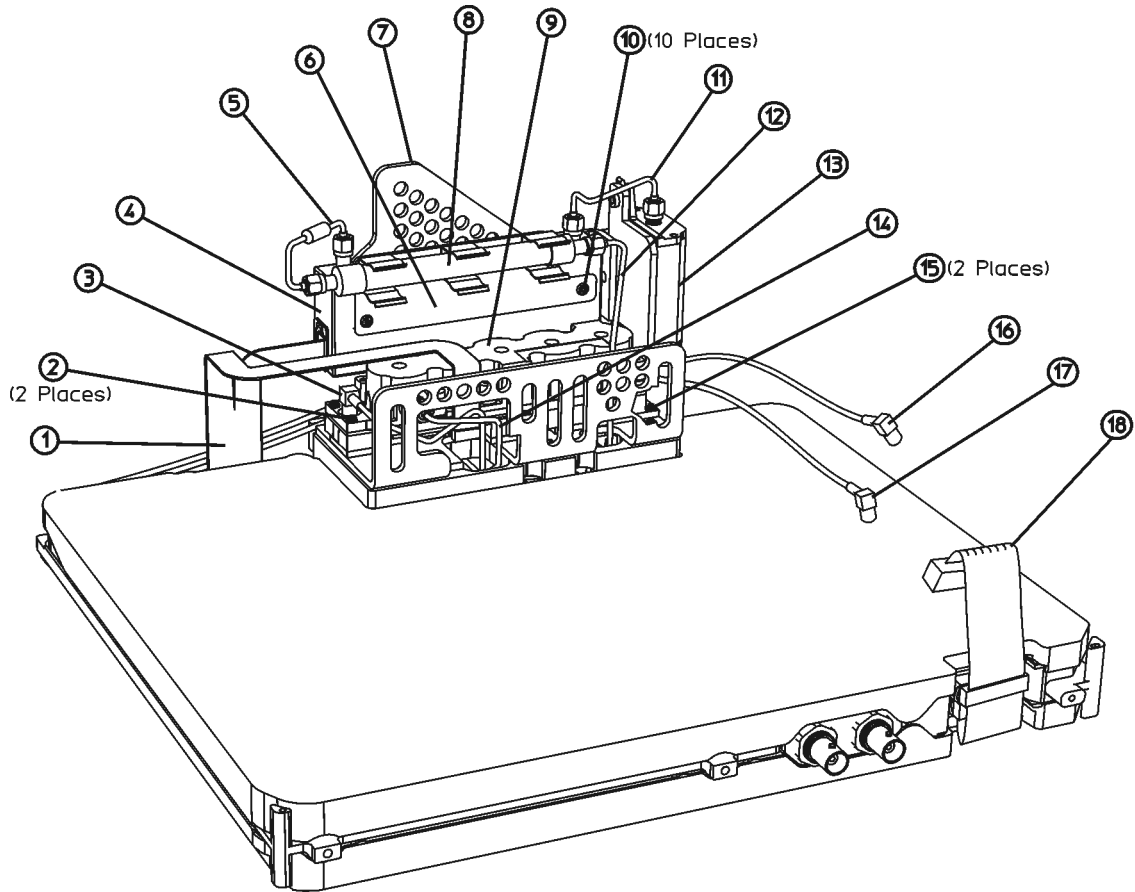

sl720b

- Remove the A8FL1 Low Pass Filter (8) from the Attenuator Bracket (7). The A8FL1 Low Pass Filter will be reused later.
- Remove semi-rigid coax cable W9 (14) that connects from the A8A2 Second Converter (9) to the A8A1 3.0 GHz RF Assembly. This cable will be reused later.
- Remove the four screws securing the A8A2 Second Converter (9) to the Attenuator Bracket (7). Two of the screws (2) will be 22 mm long, and the other two screws (15) will be 10 mm long. Save these screws; they will be reused later.
- Disconnect the ribbon cable W5 (1) from the A8A2 Second Converter (9), A8A5 Input Attenuator (5) and A8A1 3.0 GHz RF Assembly. This cable will not be reused.
- Lift the A8A2 Second Converter (9) with W11 (3) still attached from the Attenuator Bracket (7). The A8A2 Second Converter will be reused later.

Remove Attenuator Bracket

1. Position the 3.0 GHz RF Assembly as shown in Figure 16. Disconnect the semi-rigid coax cable, W7 (3) between the A8A3 DC Block and the A8J1 Input Connector.
2. Position the 3.0 GHz RF Assembly so that the top of the A8A1 is lying flat on the work surface and the attenuator bracket is hanging downward over the edge of the work surface.

Figure 16 Remove the Attenuator Bracket

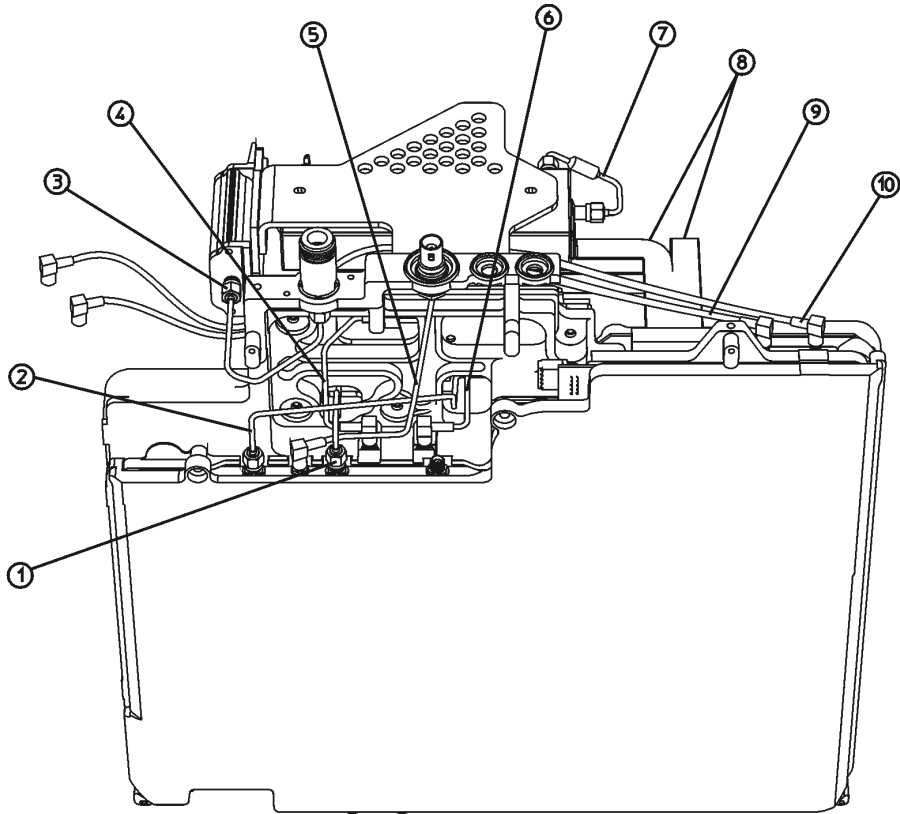

si714b

3. Remove the four 8 mm long screws securing the Attenuator Bracket to the “mid section” of the A8A1 3.0 GHz RF Assembly. Save these screws; they will be reused later. There is a small Velcro pad securing the Attenuator Bracket from the mid section, so the Attenuator Bracket will not immediately come off once the screws are removed. Gently pull downward on the Attenuator Bracket to release it from the mid section of the A8A1 3.0 GHz RF Assembly.
4. The A8A5 Input Attenuator and A8A3 DC Block attached to the Attenuator Bracket will not be reused.

Assemble Option UKB Microwave RF Assembly

1. Lay the A8A2 Second Converter flat on the work surface with flexible coax cable W11 to the left and pointing towards the front of the work surface. Lay the Micro Bracket next to the A8A2 Second Converter, with the tall part of the bracket towards the rear.
2. Insert the two 22 mm long screws removed earlier in the two mounting holes along the left side of the A8A2 Second Converter. Insert the two 10 mm long screws removed earlier in the two mounting holes along the right side of the A8A2 Second Converter.
3. Refer to Figure 17. Set the A8A2 Second Converter (2) into the Micro Bracket (1) as shown.

Figure 17 A8A2 Second Converter Installation

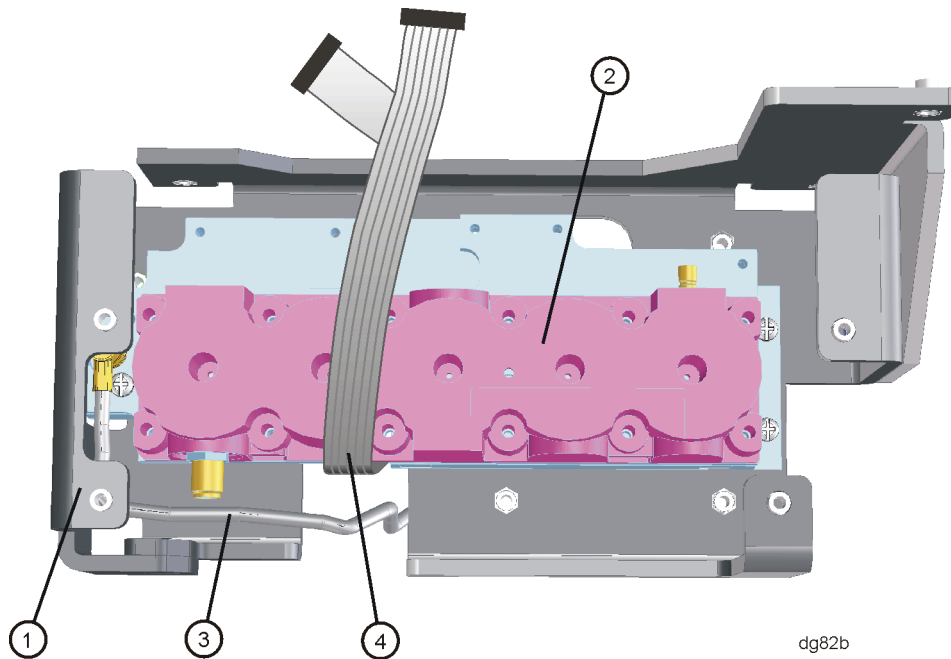

4. Tighten the screws securing the A8A2 Second Converter (2) to the Micro Bracket (1) to 9 inch-pounds.
5. Locate the W5 Attenuator and Second Converter Power and Control Cable in the kit. Note that this cable has a 24 pin connector on one end and a 10-pin and a 14-pin connector on the other end. Connect the 10-pin connector (4) to the A8A2 Second Converter (2).
6. Lay the A8A1 3.0 GHz RF Assembly bottom-side down on the work surface. Set the Micro Bracket onto the Mid Section. It will be held in place temporarily by the Velcro on each piece.
7. Flip the A8A1 3.0 GHz RF Assembly over and secure the Micro Bracket to the Mid Section using the four 8 mm long screws removed in step 3 of Removing the Attenuator Bracket. Torque these screws to 9 inch-pounds.
8. Lay the W5 ribbon cable over the top of A8A2 Second Converter so that the other end of the cable is towards the front of the RF Assembly.
9. Route flexible coax cable W11 through the hold in the Mid Section near the center, rear, of the A8A2 Second Converter. Connect the other end of W11 to A8A1A1P2.
10. Connect semi-rigid coax cable W9 (removed in step 7 of the Remove Low Pass Filter and Second Converter

procedure) between A8A2J1 and A8A1A2 J3. Torque the connectors to 10 inch-pounds.

11. Route flexible cable W2 (still connected to the A8A1A1P5 of the 3.0 GHz RF Assembly) between the front of the Micro Bracket and the A8A2 Second Converter. The cable should exit the Micro Bracket to the left.
12. Refer to Figure 18. Attach the A8FL1 Low Pass Filter (1) to the Sub Bracket (2) using the Filter Clamp (3) and two 8.0 mm pan head screws (4) supplied in the kit. Torque the screws to 9 inch-pounds.
13. Attach the A8A5 Input Attenuator (5) included in the kit to the Sub Bracket (2) using two 8.0 mm pan head screws (6) supplied in the kit. Note the orientation of the power and control connector (7) on the A8A5 Input Attenuator shown in Figure 18. Torque the screws to 9 inch-pounds.

Figure 18 Attaching the Low Pass Filter and Input Attenuator

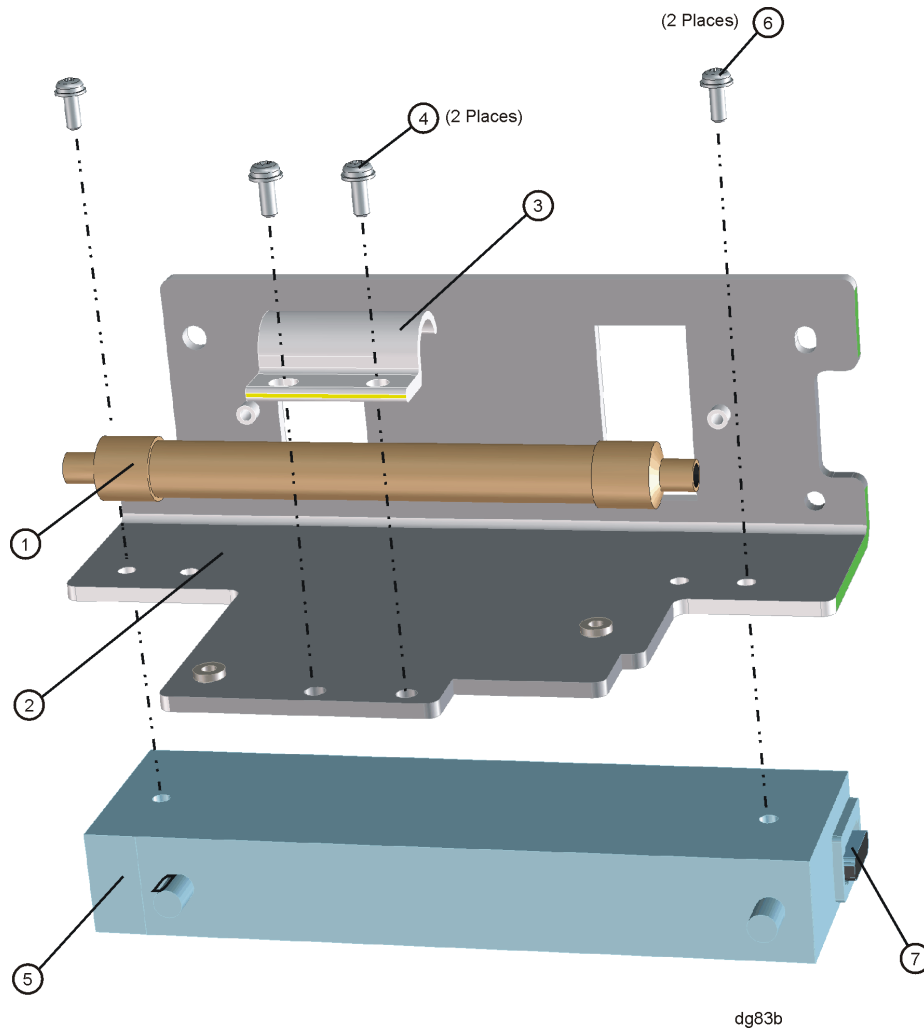

14. Refer to Figure 19. Attach the Sub Bracket (1) to the Micro Bracket (2) using the four 3.0mm x 10mm long pan head Torx screws included in the kit. Torque the screws to 9 inch-pounds.

Figure 19 **Attaching the Sub Bracket**

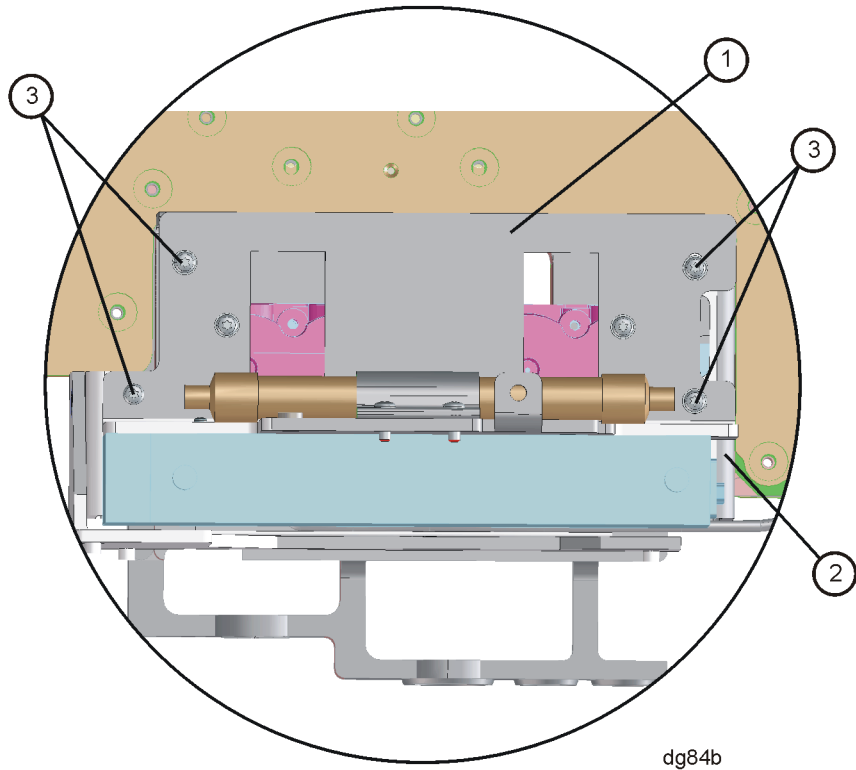

15. Refer to Figure 20. Connect the 24-pin connector end of ribbon cable W5 to A8A1A1P7 (1).

Figure 20 **Ribbon Cable and RF Cables**

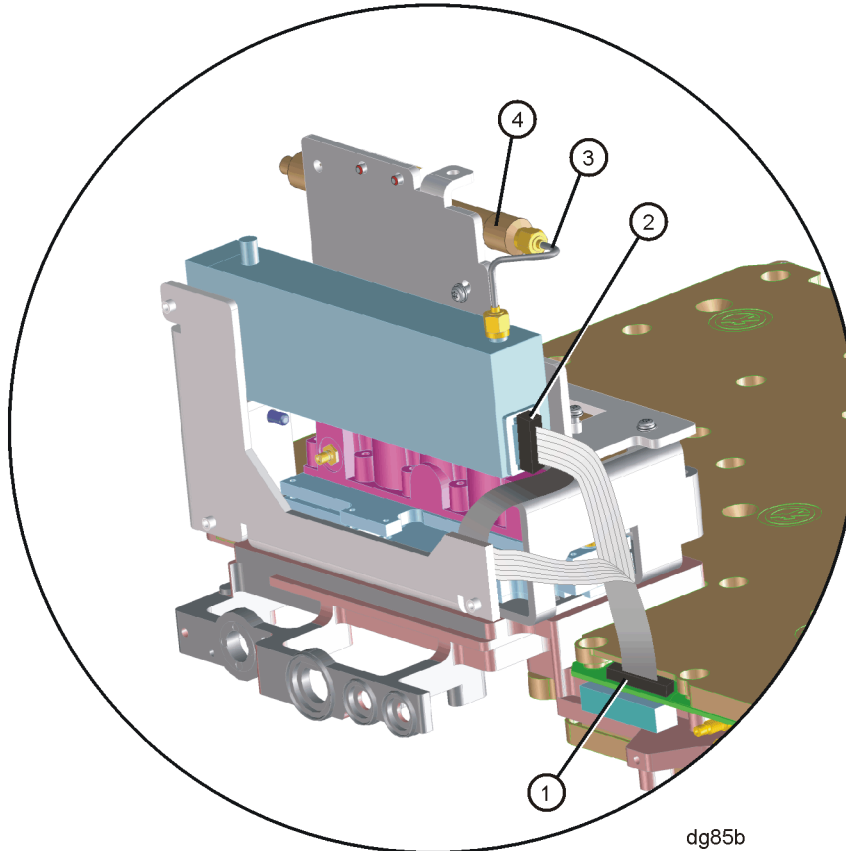

dg85b

16. Connect the 14-pin connector end of ribbon cable W5 to the A8A5 Input Attenuator (2).

17. Locate semi-rigid coax cable W15 in the kit. Connect W15 (3) between one end of A8FL1 Low Pass Filter (4) and the A8A5 Input Attenuator. Torque the connectors to 10 inch-pounds.

18. Locate semi-rigid coax cable W35 in the kit. Connect W35 between the other end of A8FL1 Low Pass Filter and A8A1A2J2. Torque the connectors to 10 inch-pounds.

19. Locate semi-rigid coax cable W6 in the kit. Connect W6 between the remaining connector on the A8A5 Input Attenuator and the A8J1 Input Connector. Torque the connectors to 10 inch-pounds.

20. Refer to Figure 21. Connect W10 (1) to A8A2J4 of the Second Converter.
21. Check the routing of semi-rigid coax cables W6 (2), W35 (3), and W9 (4).

Figure 21 **Semi-Rigid Cable Connections**

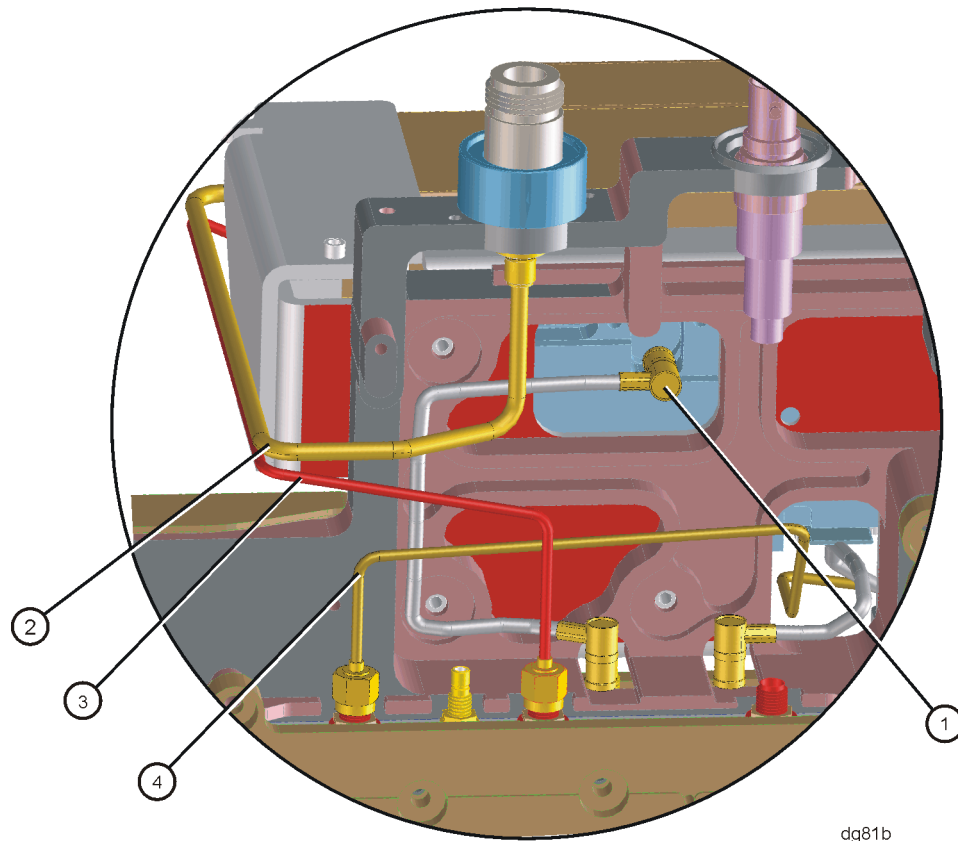

dg81b

Replace A8 3.0 GHz RF Assembly

1. Position the analyzer upside down on the work surface.
2. Tuck the cables away behind the microcircuits of the RF assembly.
3. Lower the RF assembly onto the chassis taking care not to pinch any cables.
4. Refer to Figure 22. Replace the six screws (1) securing the RF assembly to the chassis, and tighten them to 9 inch-pounds.

Figure 22 **Replace the RF Deck Screws**

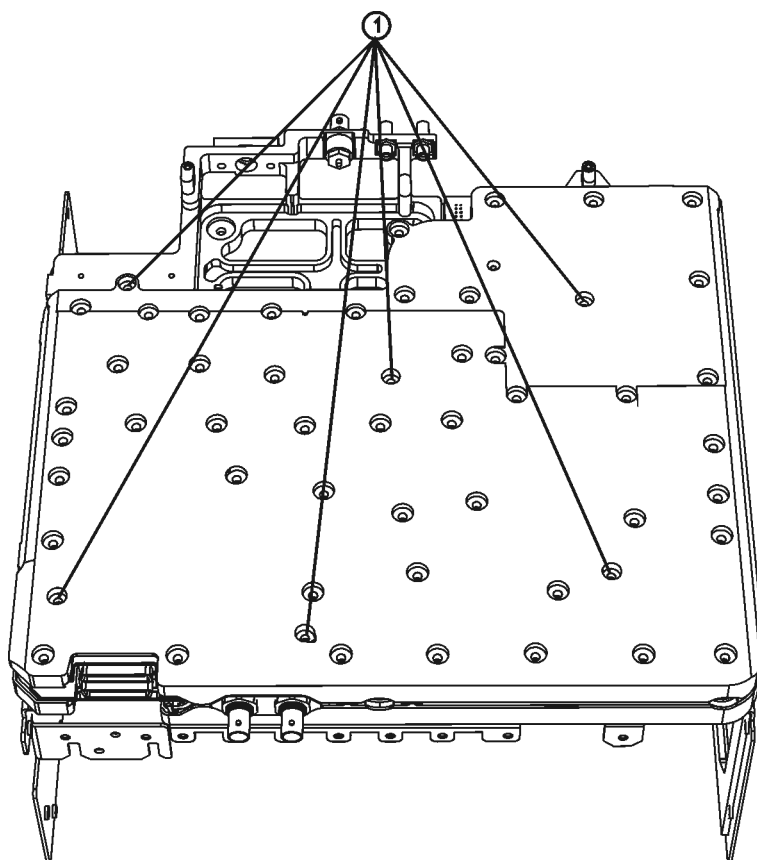

sl779b

5. If the analyzer has a tracking generator, refer to Figure 23 and reconnect the cables (1) and (2) to it and tighten the SMA connector to 10 inch-pounds.

Figure 23 Put the RF Assembly Onto the Chassis

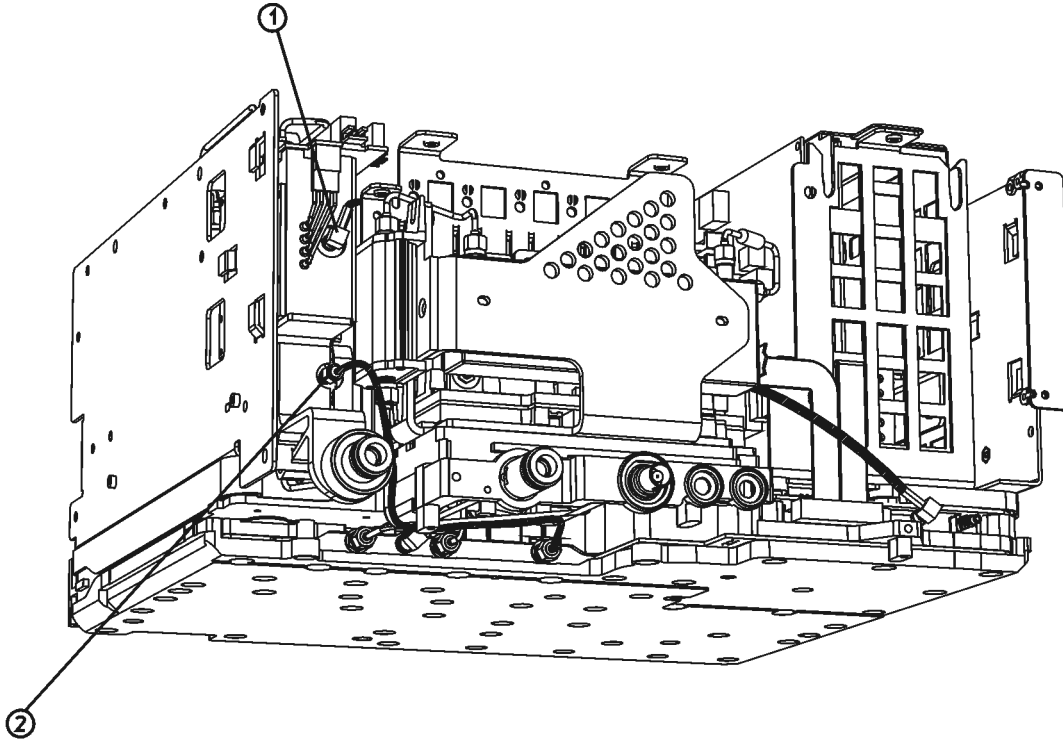

sl789b

6. Refer to Figure 24. Connect the SMB cable (1) to the IF assembly.
7. Connect the RF assembly ribbon cable (2).

Figure 24 **Connect the RF Assembly Ribbon Cable and SMB Cable**

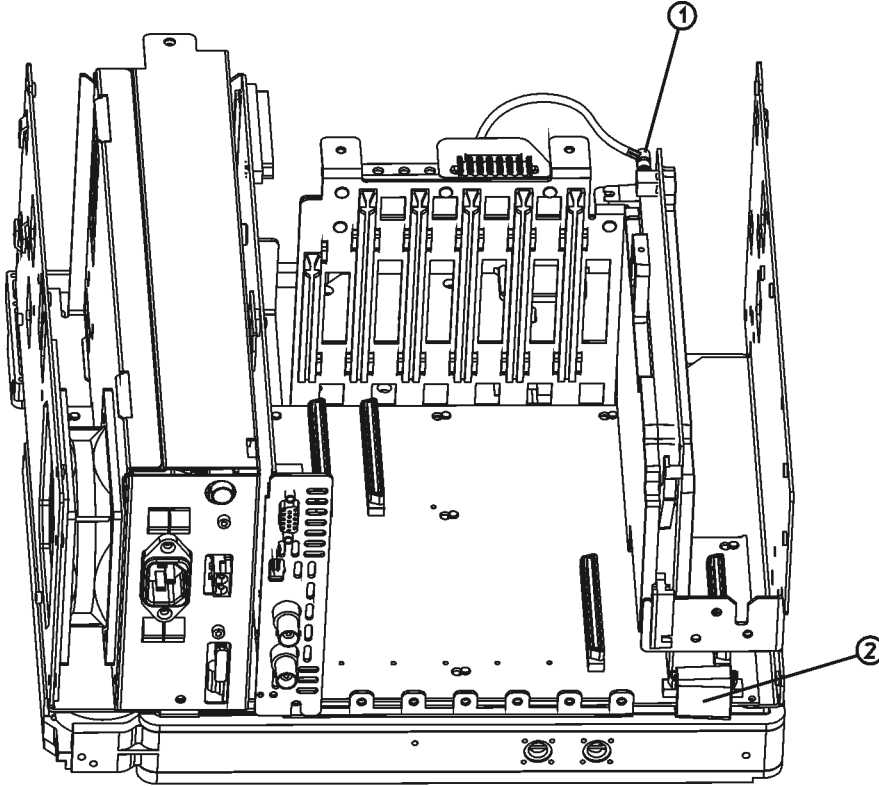

sl771b

Replace A1A1 Front Panel Interface Board

1. Refer to Figure 25. Place the front panel interface board (11) in the correct position in the front frame assembly. Make sure the water seal is in place around the volume control shaft.
2. Replace the four screws that secure the board to the front frame. Tighten them to 9 inch-pounds.

Figure 25 Front Frame Assembly Parts

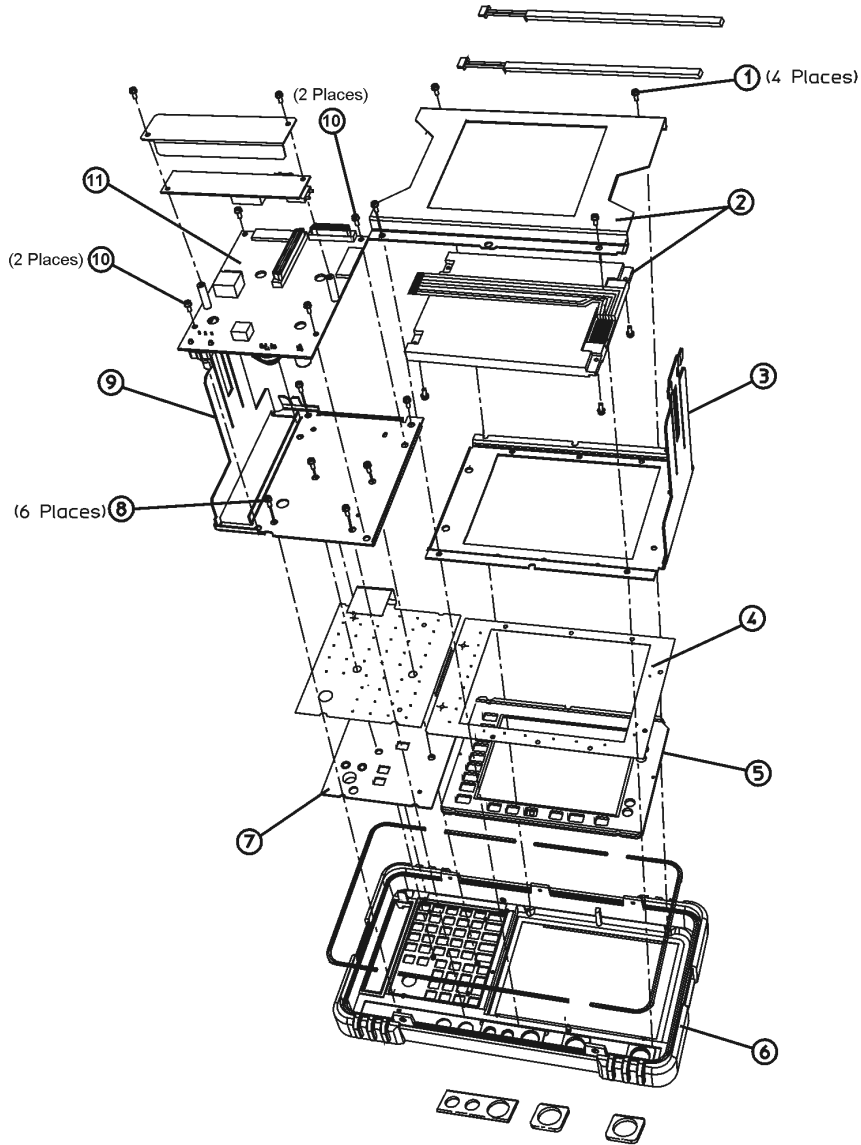

j173a

3. Refer to Figure 26. Connect the W3 display ribbon cable (2) to the front panel interface board.

TIP An easy way to insert this delicate cable into the connector is to place your finger on the cable, in the center of the LCD display, and gently slide the cable toward the connector until they align. Then, providing guidance with the other hand as necessary, slide the cable until the end slips into the connector.

Ensure the cable end is seated completely and is aligned straight within the connector body.

Continue to hold the cable in place with your finger, and with the other hand gently press the locking tabs (5) into place.

If you experience display problems, check this connection.

4. Reconnect the two 2-wire backlight cables (1) to the inverter board, making sure that the cables are dressed away from the openings for the control knobs.
5. Press the volume and RPG knobs onto their control shafts.

Figure 26 Connecting the Front Frame Wiring Connections

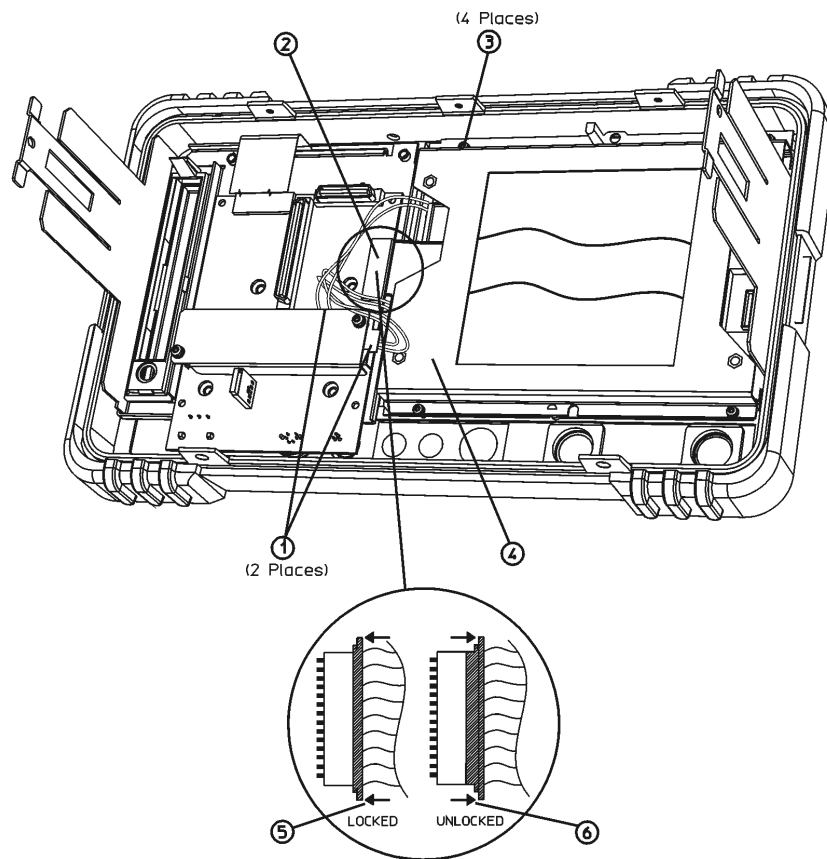

sl748b

Replace Front Frame Assembly

1. Align the A1 front frame subpanel rails with the chassis as shown in Figure 27.

Figure 27 Front Frame Assembly Replacement

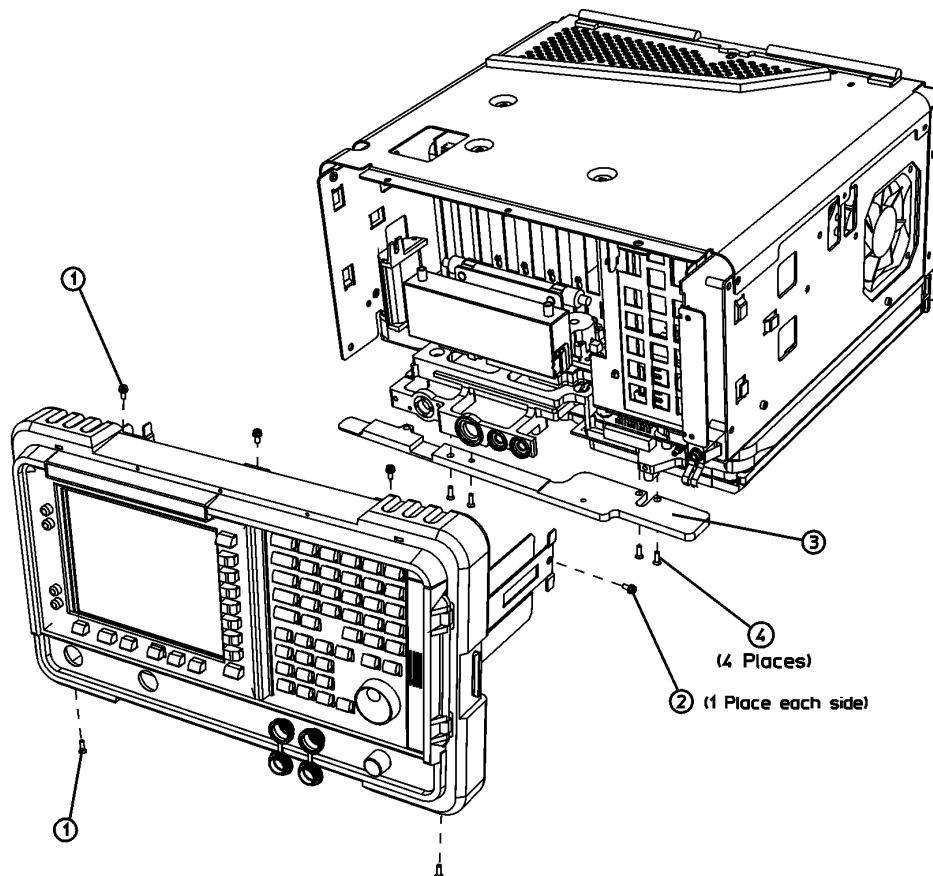

sl7118b

2. Refer to Figure 28. Connect the ribbon cable (1) to the front frame assembly.

NOTE If Option B7B is installed, there will be two ribbon cables to connect. Be sure to use the outermost connectors on the B7B ribbon cable, as the inner connectors are grounds only. These grounds were designed to suppress EMI.

3. Carefully slide the front frame toward the chassis, assuring the ribbon cable(s) are not pinched between assemblies, and the RF input connector lines up correctly with the opening in the front frame.

Figure 28 Front Frame Ribbon Cable

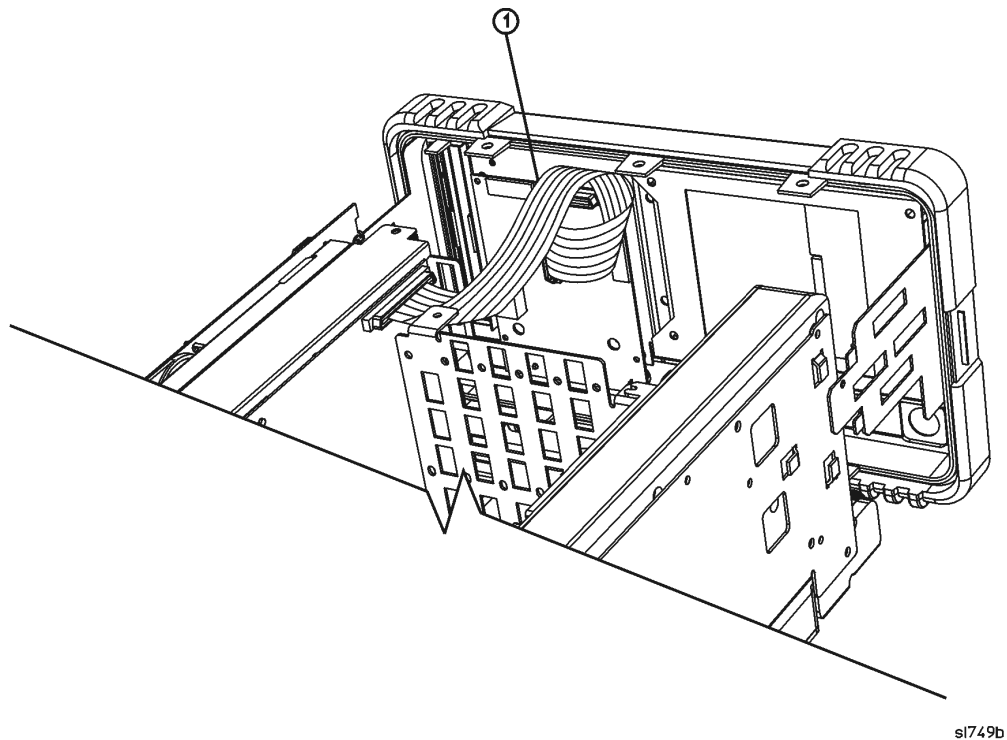

sl749b

4. Refer to Figure 27. Replace the screws that secure the front frame to the chassis (2) and to the RF assembly (1). Tighten them to 9 inch-pounds.

Replace Chassis Cover

1. Carefully position the chassis cover (1) on the instrument as shown in Figure 29, then lower onto the instrument.
2. Replace the 17 screws (2) and (3) as indicated on the instructions on the chassis cover. Tighten the screws to 9 inch-pounds.

Figure 29 Chassis Cover Replacement

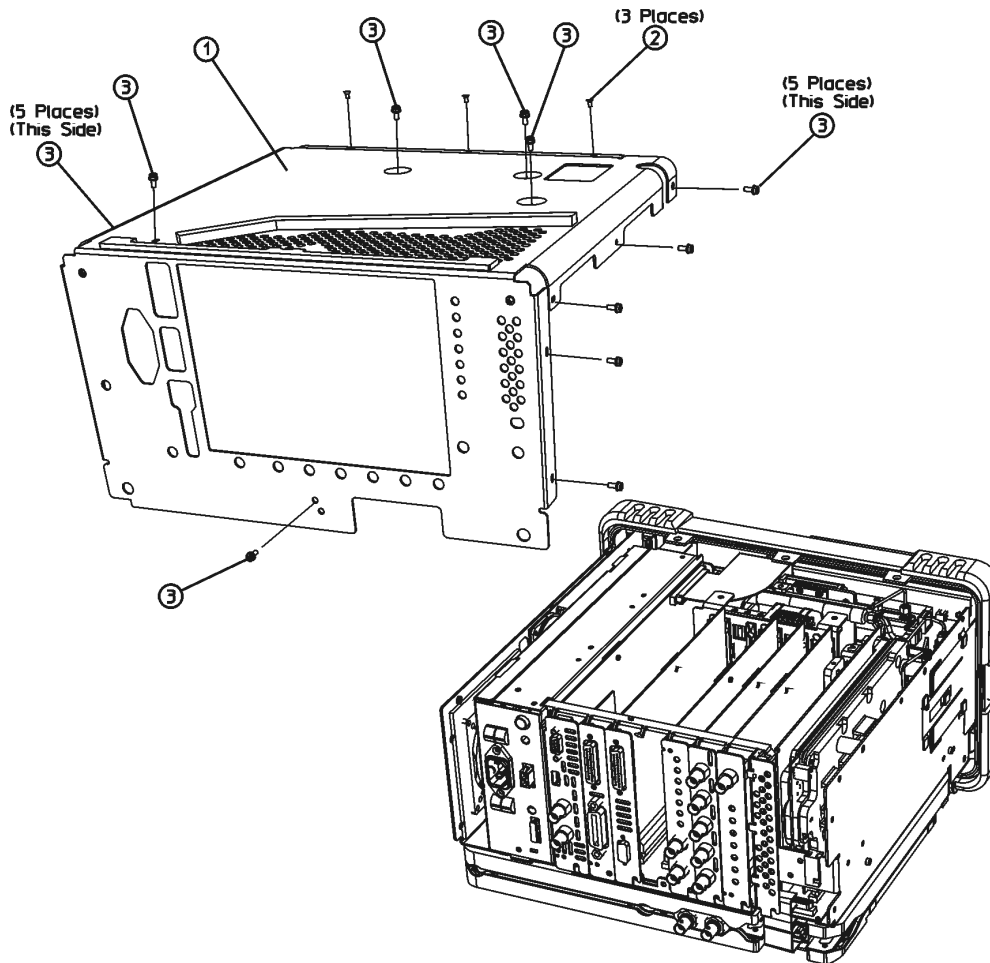

d172b

Replace Dress Cover

1. Refer to Figure 30. Carefully place the spectrum analyzer on the work surface with the front frame (3) facing down.
2. Replace the dress cover, matching the grill (8) on the bottom of the dress cover to the bottom of the analyzer.
3. Fit the leading edge of the dress cover completely into the slot (9) on the back of the front frame assembly.
4. Replace the rear frame assembly (6) using the four screws (5) to fasten the rear frame to the analyzer. Tighten them to 21 inch-pounds.

Figure 30 Dress Cover, Rear Frame Replacement

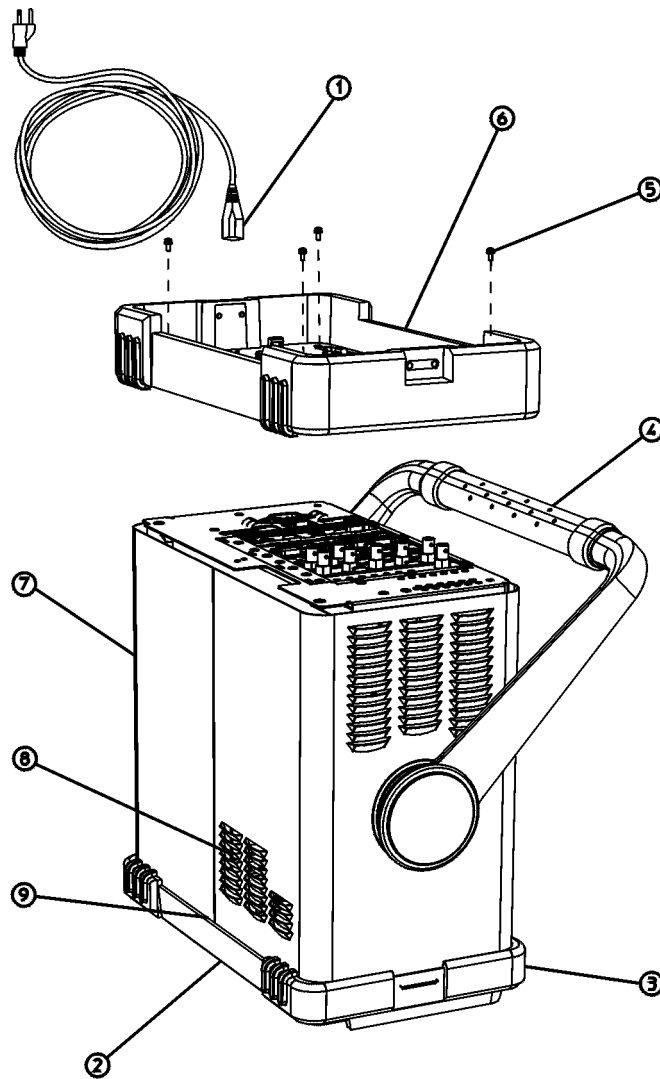

s1745b

Firmware Revision Verification

1. Turn on the analyzer and wait for the power-on alignments to complete. Check that there are no error messages displayed.
2. Press **System, More, Show System**. Make a note of the firmware revision.
3. If the firmware revision is A.05.00 or later, the firmware does not need to be upgraded and you can skip step 4 through 6. However, if the instrument being upgraded has Option B72, Expansion Memory, Agilent recommends you upgrade the instrument firmware to the current version. See steps 5 and 6.
4. If your firmware revision is prior to A.05.00, you must upgrade your analyzer firmware to be compatible with upgrade Option UKB.
5. For model E7402A, use one of the following methods:
 - Download the instrument firmware via the world-wide web at http://www.agilent.com/find/emc_firmware. This entire process of upgrading firmware will take approximately 45 minutes.
 - Receive the latest firmware upgrade disk set by ordering upgrade Option UE2.
Note: Special instructions in the Agilent ordering configurator should have made you aware of Option UE2 in case access to the internet wasn't available.
6. For model E4402B, press **System, More, Show System** and see if Option B72, Expansion Memory, is listed on the display.

If Option B72 is installed you should upgrade the instrument firmware using one of the following methods:

- Download the instrument firmware via the world-wide web at http://www.agilent.com/find/esa_firmware. This entire process of upgrading firmware will take approximately 45 minutes.
- Receive the latest firmware upgrade disk set by ordering upgrade Option UE2.
Note: Special instructions in the Agilent ordering configurator should have made you aware of Option UE2 in case access to the internet wasn't available.

If Option B72 is not installed, you should upgrade the instrument firmware using one of the following methods:

- Download the instrument firmware via the world-wide web at http://www.agilent.com/find/esa_firmware_std-mem. This entire process of upgrading firmware will take approximately 45 minutes.
- Order upgrade Option B72, which includes the expansion memory and the latest ESA firmware upgrade disk set.

Obtaining a License Key and Activating the Option

The entitlement certificate supplied in this kit allows you to obtain a license key from our Agilent website so you can enable this upgrade option. Once you have retrieved the license key, you can begin the process of activating the option.

1. Press **System, More, More, Licensing, Option**. When you press **Option**, the alpha editor will be activated. For instructions on using the alpha editor, refer to the analyzer User's Guide.
2. Use the alpha editor to enter the three-character designation for the option, in this case, "UKB", that you want to activate.
3. Press **Enter** when done.
4. Press **License Key**. When you press **License Key** the alpha editor will be activated.
5. Use the alpha editor and the numeric keypad to enter the 12-character license key number (for example: D7C374DABD5B) for the option that you want to activate.
6. Press **Enter** when done.
7. Press **Activate** to turn on the option.
8. If the option and license key entries were correct, a message stating "Option Activated" will appear on the analyzer display.

Adjustments and Performance Verification

1. Verify that Option UKB was activated by pressing **System, More, Show System**. Verify that there is an entry which reads, "UKB: Low Freq Extension".
2. Perform the Frequency Response Adjustment, located in the Adjustment Software.
3. Perform the following performance verification tests, located in the analyzer Calibration Guide:
 - Frequency Response
 - Displayed Average Noise Level
 - Residual Responses
4. If you have problems performing either of these tests, get in touch with the nearest Agilent Technologies sales and service office listed in the troubleshooting chapter of the analyzer User's Guide.